

Feynman Diagrams via TikZ

Flip Tanedo

*Institute for High Energy Phenomenology,
Newman Laboratory of Elementary Particle Physics,
Cornell University, Ithaca, NY 14853, USA*

E-mail: pt267@cornell.edu

This version: March 11, 2013

Abstract

These are sample Feynman diagrams.

Contents

1	QED	1
2	QED+ μ	2
3	QED+Z+ μ	3
4	Blob diagrams	3
5	Coleman Weinberg	3
6	't Hooft operator	4
7	Anomaly	4
8	SUSY Cascade	5
9	Hadronic interactions	5
10	Flavor (box and penguins)	6

11 Multiloop	6
12 Renormalization	6
13 Cross section	6
14 Z boson	7
15 W boson	7
16 Dark Matter	8
17 Coleman Weinberg	8

1 QED

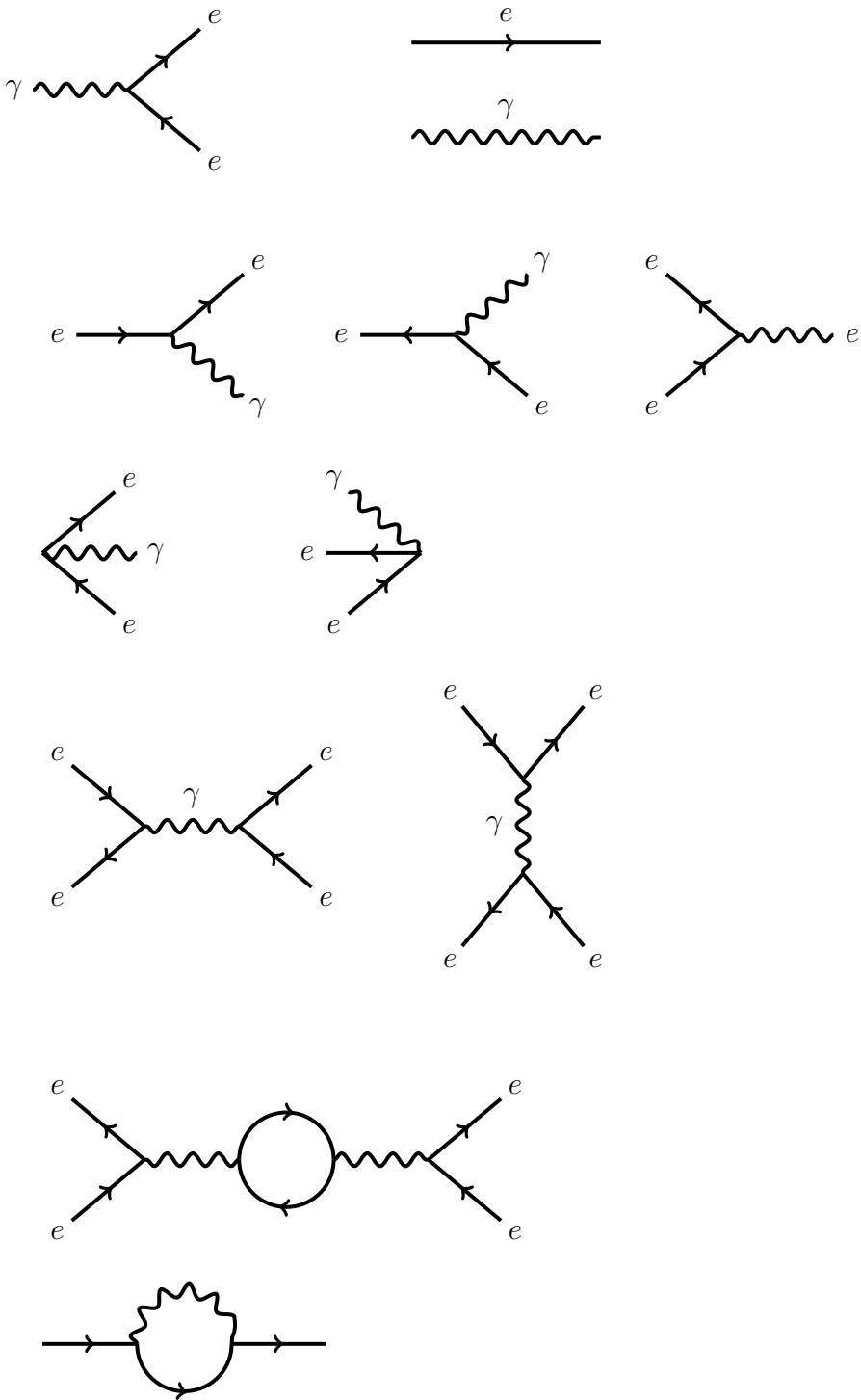

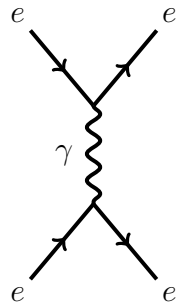
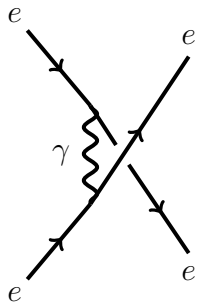
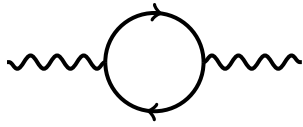

2 QED+ μ

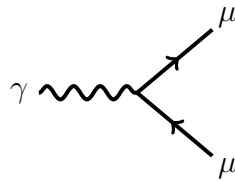
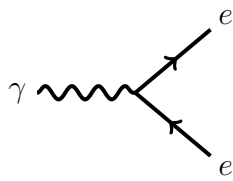
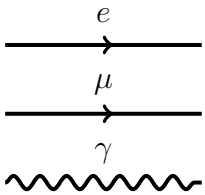

Electrons to muons

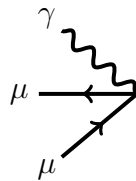
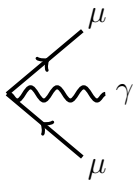
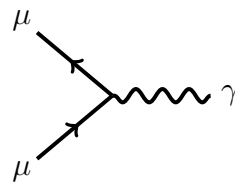
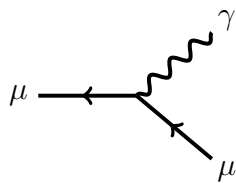
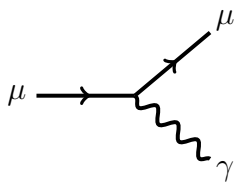
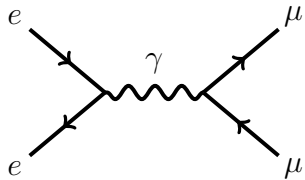

3 QED+Z+ μ

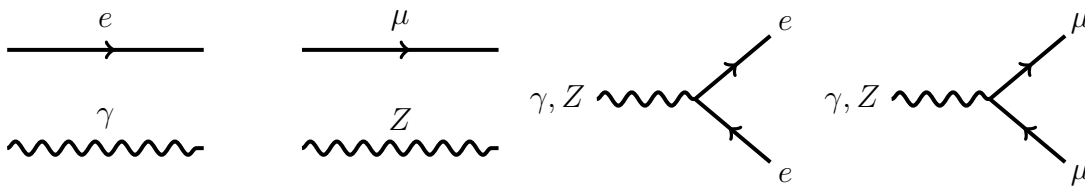

Electrons to muons via Z

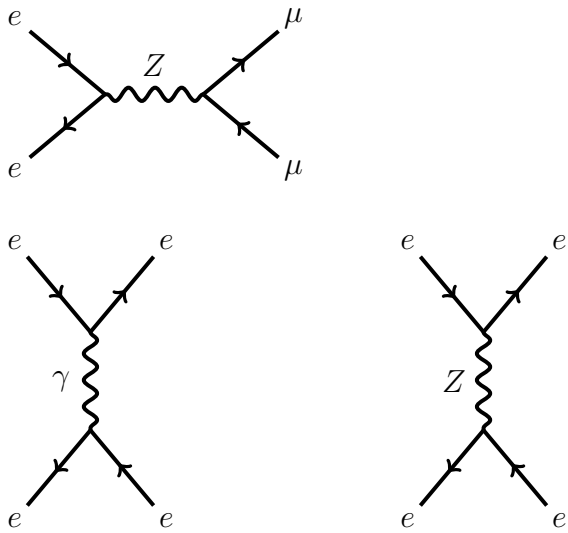

4 Blob diagrams

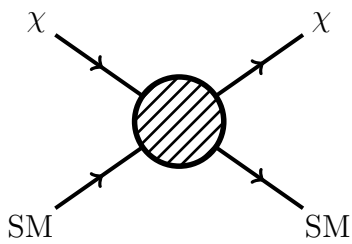

5 Coleman Weinberg

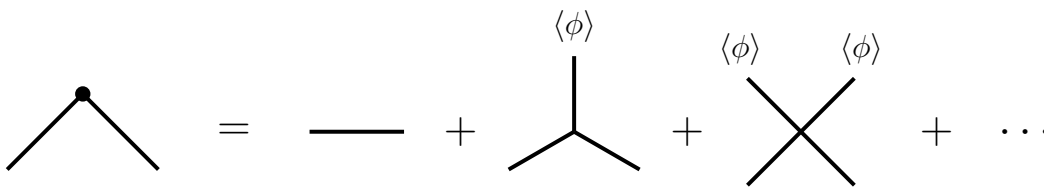

6 't Hooft operator

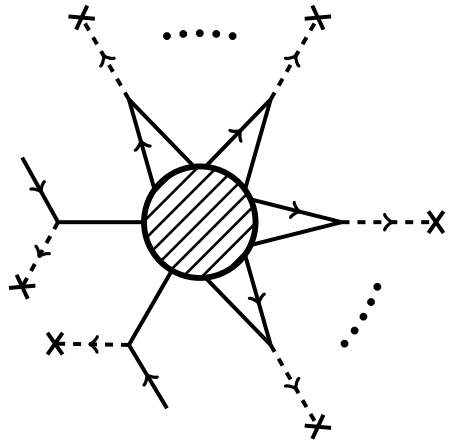
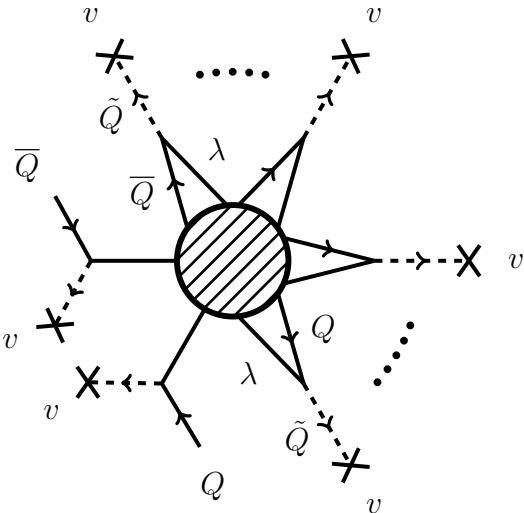

7 Anomaly

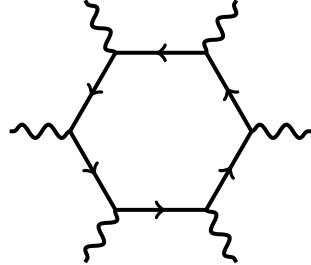
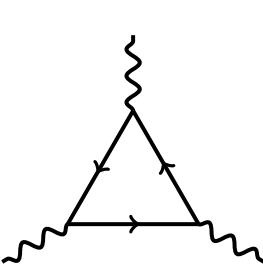

8 SUSY Cascade

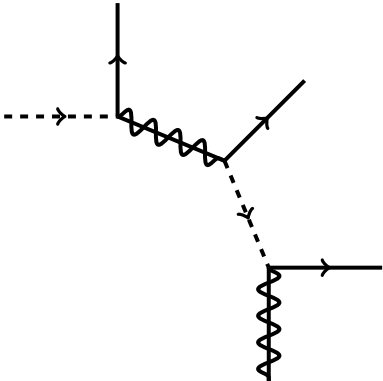

9 Hadronic interactions

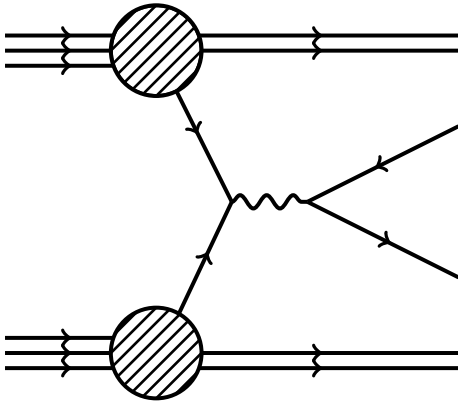
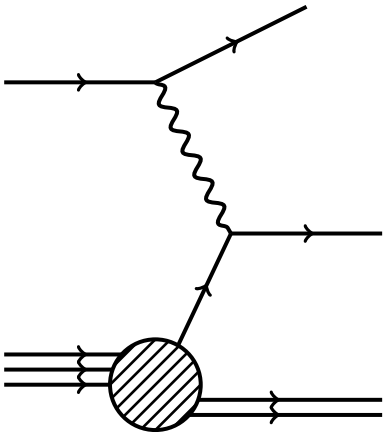

10 Flavor (box and penguins)

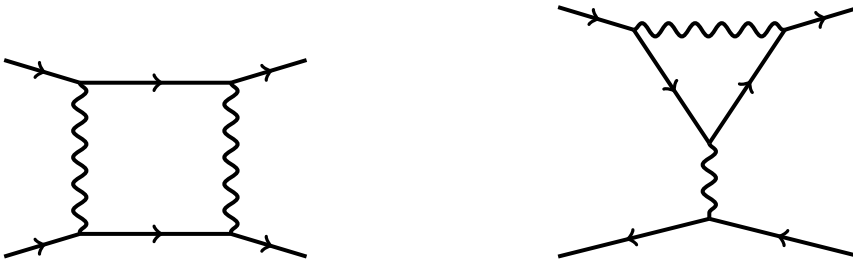

11 Multiloop

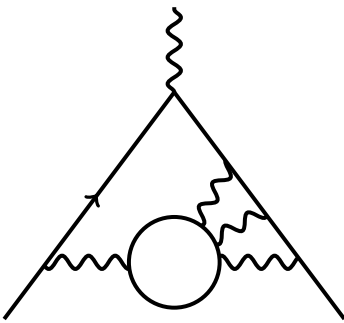

12 Renormalization

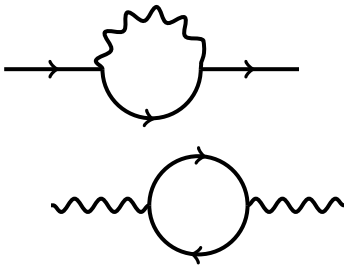

13 Cross section

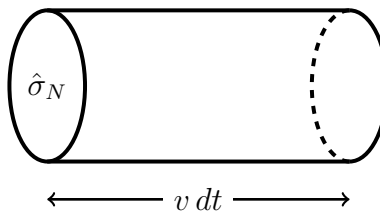

14 Z boson

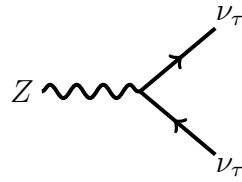
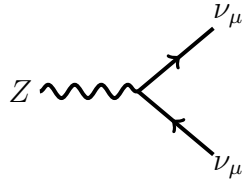
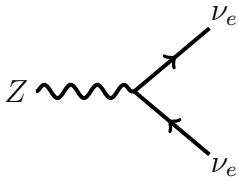
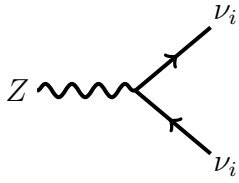

15 W boson

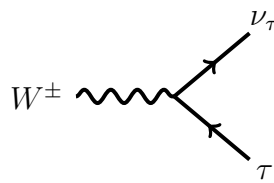
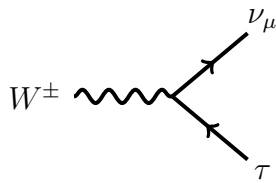
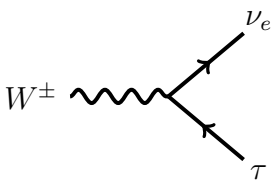
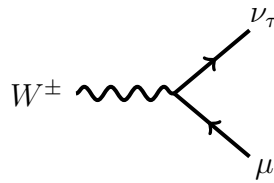
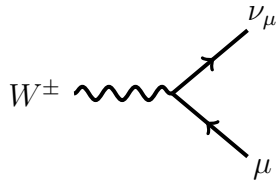
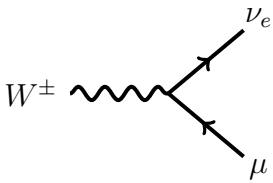
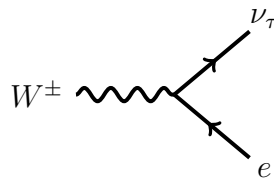
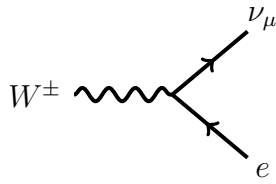
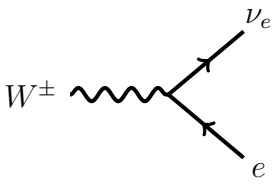
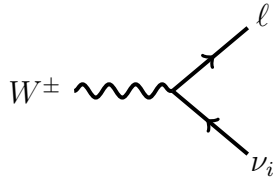
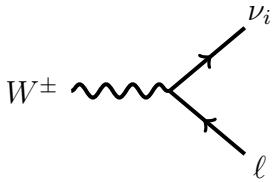

16 Dark Matter

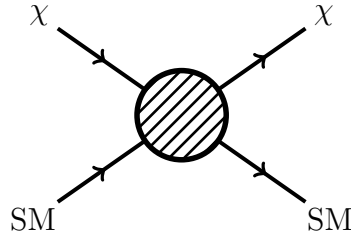

17 Coleman Weinberg

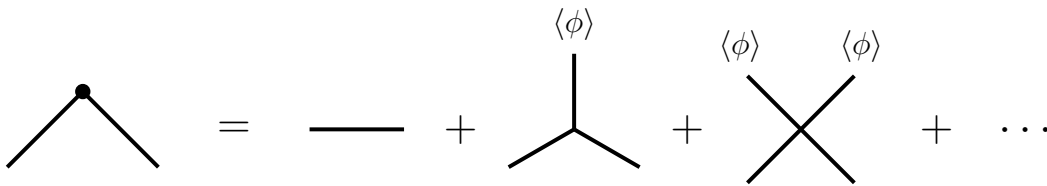

Acknowledgements

... This work is supported in part by the NSF grant number PHY-0355005, an NSF graduate research fellowship, and a Paul & Daisy Soros Fellowship For New Americans. The contents of this article do not necessarily represent the views of either institution.